

PAPER • OPEN ACCESS

Study of dynamically catalytic system on humic acid phototransformator

To cite this article: Yuni Aulia Djasli *et al* 2020 *J. Phys.: Conf. Ser.* **1481** 012037

View the [article online](#) for updates and enhancements.

You may also like

- [Development of an Electrochemical Sensor Based on LbL Films of Pt Nanoparticles and Humic Acid](#)
Monalisa dos Santos, Ellen Christine Wrobel, Vagner dos Santos et al.
- [Effect of humic acid on transformation of soil heavy metals](#)
Shengzhe Wu, Rui Li, Shuyang Peng et al.
- [Application of humic acid and Vesicular Arbuscular Mycorrhiza \(VAM\) for growth and production of soybean](#)
A H Bahrn, A Mollah and N H Khotimah



The Electrochemical Society
Advancing solid state & electrochemical science & technology

241st ECS Meeting

May 29 – June 2, 2022 Vancouver • BC • Canada

Extended abstract submission deadline: Dec 17, 2021

Connect. Engage. Champion. Empower. Accelerate.
Move science forward



Submit your abstract



Study of dynamically catalytic system on humic acid phototransformator

Yuni Aulia Djasli¹, Devi Purnamasari², and Rahadian Zainul^{3*}

¹Chemistry Laboratory FMIPA, Universitas Negeri Padang, Indonesia

²Hospital Administration and Public Health, STIKES Awal Bros Pekanbaru, Indonesia

³Physical Chemistry Laboratory, FMIPA, Universitas Negeri Padang, Indonesia

*rahadianzmsiphd@fmipa.unp.ac.id

Abstract. This research was conducted using a phototransformator reactor which was used to degrade humic acid with photocatalysts of calcined CuO plates for 1 hour at 4000C. This reactor is designed in hexagonal shape made of glass with a thickness of 3 mm which has a rotation with speeds of 1000, 1500 and 2000 rpm, in this reactor filled with 200 mL of humic acid. The light source used is direct sun, the catalytic process is carried out through the process of degradation of humic acid using a reactor. The time variations used are 1, 2, 3, 4 and 5 hours. Absorption of visible light of humic acid before and after degradation was 265 nm. The results show that in direct sunlight the highest average value of %degradation is 55.66% at a velocity of 1000 rpm

1. Introduction

Semiconductors are conductivity materials that are between conductors and insulators. Electron semiconductors will be excited on the surface of the material due to the help of light and will trigger a chemical reaction [1,17-28]. Humic acid is a heterogeneous organic compound that has a high molecular weight and is difficult to degrade and is generally yellow to black [2, 13-15]. This color will increase in intensity if there is an iron metal bound to the organic acid [3]

The transformation of humic acid was also examined by N.C birben, C.M et all [4] after irradiation with UV 254 nm to 365 nm. The optical and electrochemical properties of humic acid are reported to undergo changes, as a function of species and aromatic properties after degradation or transformation [5]. Humic acid which is exposed to visible light and the catalyst causes the degradation of the greater the intensity of light, the better the degradation process [6, 13-15]. The use of sunlight as a photocatalyst activator is a promising thing, considering that the sun is the largest energy source in nature and can be obtained for free [7, 17-28].

Phototransformator with CuO plates has been developed to be one of the best photocatalysts for the environment [8]. The CuO plate has the advantages of p-type semiconductor material [9] because it has a band gap of around 1.2 - 1.6 eV, capable of working on visible light or direct sunlight, can increase photocatalyst activity, low manufacturing costs and abundant availability, CuO can effectively degrades color molecules, and is widely applied in industrial worlds such as gas sensors and solar cells [10].



2. Experimental Section

2.1 Tools and material

The tool used the research are Measuring Cylinder 1 L, Volumetric Flask 1 L, Watch Glass, Analytical Balance, Humic Acid Reactor, Furnace. Then the tools for characterization, XRD and SEM to determine morphology. The materials used in this study are humic acid, aquades, copper plate 0.3 mm (PT Metalindo).

2.2 Methods

2.2.1. Synthesis of Copper plate. Copper plate in the form of sheets (36.5 cm x 120 cm) is cut into pieces 2 cm wide and 7 cm. Then the copper plate is calcined in the furnace at 400°C for 1 hours, then cool for 5 hours. The Copper oxide plate is then tested with XRD and SEM after it will be installed into the reactor that is designed.

2.2.2 Making Reactor Design. Mobile photoreactor, which is clear glass with a thickness of 3 mm made of hexagonal reactor, then given a dynamo and dynamo controller (12-24V.8A DC dimmer) with electricity (2A / 12V adapter and cable) and a Tachometer to regulate RPM (DT-2234C +), then the dynamo is connected to the stirrer with a copper oxide plate with a size of 7 x 2 cm.

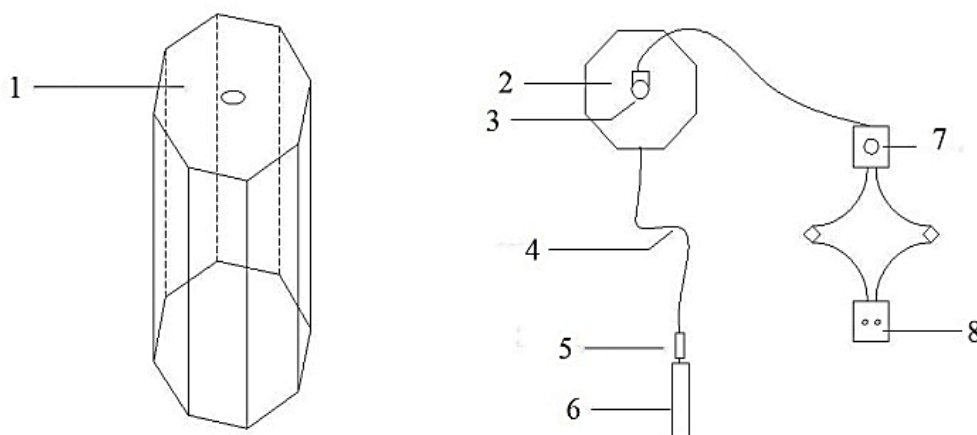

Figure 1. Photoreactormobile; (1. Parts of the lid; 2. Parts of the lid; 3. Dynamo; 4. Stirrer; 5. Plate clamp; 6. Plate; 7. Dynamo controller; 8. Plug)

2.2.3 Test of Humic Acid Photocatalyst Degradation. A total 200 mL of 20 ppm humic acid solution into the first reactor with the help of direct sun at the time of 1, 2, 3, 4, and 5 hours. Then sort absorbance by UV-Vis spectrophotometer dengan panjang gelombang 265 nm.

3. Result and Discussion

3.1. CuO plate characteristics with XRD and SEM

The CuO plate characteristics with xrd are used to determine the structure and size of the crystal [11]. XRD provides information about structure, phase, texture, crystallinity, crystal size of CuO plates [12]. The results obtained from XRD on CuO plate samples after calcining, there are two peaks in CuO and Cu₂O. In the CuO compound 80.42% and Cu₂O compounds are 77.36%.

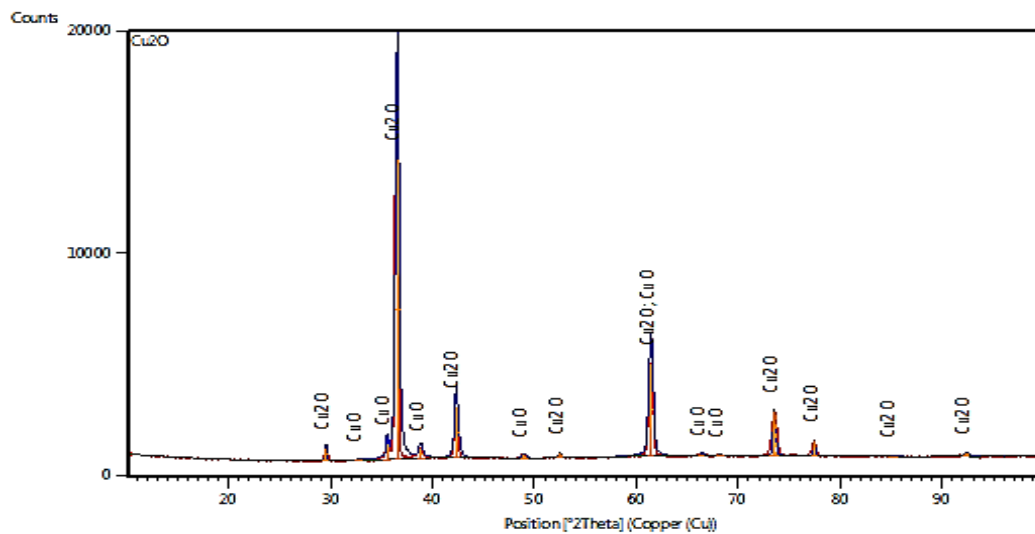
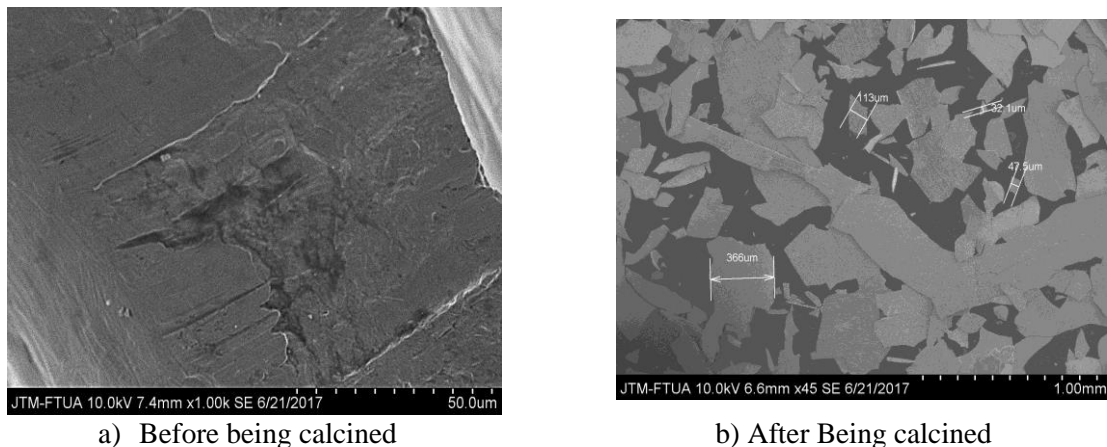

Figure 2. XRD Characteristics [29]

SEM characteristics are used to determine the surface of the sample. The results of this study were carried out before calcination and after calcination using a furnace at 400°C for 1 hour and cooled for 5 hours. The calcination process at 1 hour aims to form an oxide into CuO while if the temperature is less than 400°C it will form a plate [13, 22-23, 29]. Scanning Electron Microscope (SEM) results obtained after and before calcination at 5000x magnification can be seen in the figure 3.



a) Before being calcined

b) After Being calcined

Figure 3. SEM Characterization [22-23]

From the CuO plate surface image at 5000x magnification, it is known that the CuO plate surface after calcination for 1 hour at 400°C gets optimal results, namely oxide formation from Cu plate to CuO and changing the conductor properties for semiconductors and catalysts so that it can be used as a photocatalyst humic acid.

3.2. Effect of catalytic and dynamic for phototransformator humic acid

Phototransformator process in visible light obtained the optimum value of % D for 4 hours at a rotation speed of 1000 rpm is 57.23%, at a rotation speed of 1500 rpm the optimum value %D at 2 hours is 56.53% and at 2000 rpm the optimum value at 3 hours that is 51.51%. The results showed that the higher the rotational speed, the optimum value % D was lower due to the faster stirring process so that the interaction between CuO plate and humic acid was less, the velocity of rotation resulted in empty space

between humic acid and CuO plate so that the interaction was not fully formed. The optimum value of each speed has different times. This is related to the reflected light rays and the rotation performed [14].

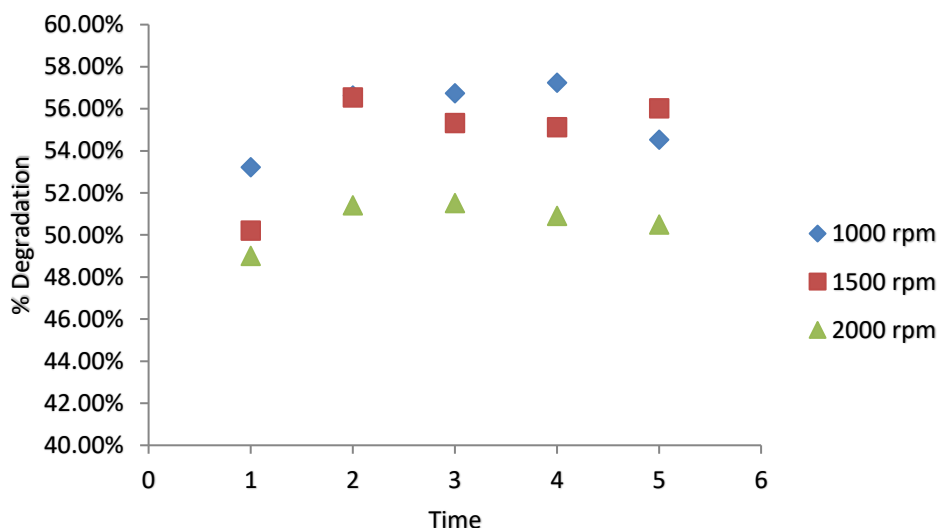

Figure 4. Effect of rotary speed and illumination time for degradation

Graphic images at a rotation speed of 1000 rpm, 1500 rpm and 2000 rpm a decrease in % Degradation, a decrease in % Degradation caused by CuO plate has reached saturation so some particles from CuO no longer participate in the degradation process of humic acid [15].

The direct process of irradiation with sunlight causes an interaction with the CuO plate photocatalyst with an OH. OH formed due to the irradiation process. The photocatalyst will react due to the energy of the photon and will be excited to form electron holes and recombinant holes. The active side of the CuO plate catalyst where recombination and electrons occur when it is used, the other molecules will survive on the surface of the CuO plate so that rotation is needed so that the molecule is released in the part that survives on the surface of the CuO Plate. Turnover causes the solution to react with oxygen faster so that % D is high.

Electrons in the conduction band on the surface of the CuO plate will react with O_2 to form superoxide radical anions and react again with absorbed water molecules to produce OH ions and in the valence band on the surface the CuO plate reacts with OH ions to form $\bullet OH$ which will degrade humic acid direct sunlight causes interaction with the CuO plate photocatalyst with an OH radical formed due to the irradiation process. The photocatalyst will react due to the energy of the photon and will be excited to form electron holes and recombinant holes. The active side of the CuO plate catalyst where recombination and electrons occur when it is used, the other molecules will survive on the surface of the CuO plate so that rotation is needed so that the molecule is released in the part that survives on the surface of the CuO Plate. Turnover causes the solution to react with oxygen faster so that % D is high.

4. Conclusion

Photocatalysts can react to direct sunlight resulting in excitation of electrons forming recombinant electrons and holes [16], the active side of the catalyst found in recombinant makes humic acid react with CuO plate so that phototransformation occurs and forms OH radicals, rotation is used so that humic acid is completely degraded and opens a closed part on the surface of the closed CuO plate. The results showed that good degradation occurred at 1000 rpm rotation, the optimum value of % D was 57.23%, while at 1500 rpm and 2000 rpm it decreased by 56.53% and 51.51%, because of the high CuO and humic acid react so that it is difficult to degrade.

References

- [1] Madjene, F., et al., *A review: titanium dioxide photocatalysis for water treatment*. Transnational Journal of Science and Technology, 2013. **3**(10): p. 1857-8047.
- [2] Kim, D., et al., *Transcriptome analysis of Pseudomonas sp. from subarctic tundra soil: pathway description and gene discovery for humic acids degradation*. Folia microbiologica, 2018. **63**(3): p. 315-323.
- [3] Klučáková, M., *Size and Charge Evaluation of Standard Humic and Fulvic Acids as Crucial Factors to Determine Their Environmental Behavior and Impact*. Frontiers in chemistry, 2018. **6**.
- [4] Birben, N., et al., *Photocatalytic degradation of humic acid using a novel photocatalyst: Ce-doped ZnO*. Photochemical & Photobiological Sciences, 2017. **16**(1): p. 24-30.
- [5] Tang, W.-W., et al., *Impact of humic/fulvic acid on the removal of heavy metals from aqueous solutions using nanomaterials: a review*. Science of the total environment, 2014. **468**: p. 1014-1027.
- [6] Zhou, X., et al., *Synergistic effects and kinetics of rGO-modified TiO₂ nanocomposite on adsorption and photocatalytic degradation of humic acid*. Journal of environmental management, 2019. **235**: p. 293-302.
- [7] Lin, Z., et al., *Modifying photocatalysts for solar hydrogen evolution based on the electron behavior*. Journal of Materials Chemistry A, 2017. **5**(11): p. 5235-5259.
- [8] Tran, T.H. and V.T. Nguyen, *Copper oxide nanomaterials prepared by solution methods, some properties, and potential applications: a brief review*. International scholarly research notices, 2014. **2014**.
- [9] Koffyberg, F. and F. Benko, *A photoelectrochemical determination of the position of the conduction and valence band edges of p-type CuO*. Journal of Applied Physics, 1982. **53**(2): p. 1173-1177.
- [10] Rao, M.P., et al., *Photocatalytic properties of hierarchical CuO nanosheets synthesized by a solution phase method*. Journal of Environmental Sciences, 2018. **69**: p. 115-124.
- [11] Height, M.J., et al., *Ag-ZnO catalysts for UV-photodegradation of methylene blue*. Applied Catalysis B: Environmental, 2006. **63**(3-4): p. 305-312.
- [12] Litvin, V.A. and B.F. Minaev, *The size-controllable, one-step synthesis and characterization of gold nanoparticles protected by synthetic humic substances*. Materials Chemistry and Physics, 2014. **144**(1-2): p. 168-178.
- [13] Zainul, R., Oktavia, B., Dewata, I., Efendi, J. 2018. Thermal and Surface Evaluation on the Process of Forming a Cu₂O/CuO Semiconductor Photocatalyst on a Thin Copper Plate. IOP Conference Series: Materials Science and Engineering 335(1),012039
- [14] Zainul R 2016 Effect of Temperature and Particle Motion Against the Ability of ZnO Semiconductor Photocatalyst in Humic Acid Der Pharmacia Lettre 8 pp. 120-124
- [15] Zainul R 2016 Determination of the Half-Life and the Quantum Yield of ZnO Semiconductor Photocatalyst in Humic Acid Der Pharmacia Lettre 8 pp. 176-179
- [16] Abdullah, H., et al., *Modified TiO₂ photocatalyst for CO₂ photocatalytic reduction: An overview*. Journal of CO₂ Utilization, 2017. **22**: p. 15-32.
- [17] Zainul R, Alif A, Aziz H, Yasthopi A, Arief S, Syukri 2015 Photoelectrosplitting Water for Hydrogen Production Using Illumination of Indoor Lights, Journal of Chemical and Pharmaceutical Research 7(11) pp. 57-67
- [18] Chaidir, Z., Syafrizayanti, Hillman, P.F., Zainul, R.. 2016. Isolation and identification of freshwater microalgae potentially as antibacterial from Talago Biru, Koto Baru, West Sumatera. Der Pharmacia Lettre 8(20), pp. 157-165
- [19] Zainul, R., Dewata, I., Oktavia, B., 2019. Fabrication of hexagonal photoreactor indoor lights. Journal of Physics: Conference Series 1185(1),012007
- [20] Zainul R 2016 Design and Modification of Copper Oxide Electrodes for Improving Conversion Coefficient Indoor Lights (PV-Cell) Photocells Der Pharma Chemica 8 pp. 388-395

- [21] Putri, G.E., Arief, S., Jamarun, N., Gusti, F.R., Zainul, R., 2019. Microstructural analysis and optical properties of nanocrystalline cerium oxides synthesized by precipitation method. *Rasayan Journal of Chemistry* 12(1), pp. 85-90
- [22] Zainul, R., Oktavia, B., Dewata, I., Efendi, J.. 2018. Study of Internal Morphology on Preparation of Cu₂O Thin-Plate using Thermal Oxidation. *Journal of Physics: Conference Series* 1116(4),042046
- [23] Tamarani, A., Zainul, R., and Dewata, I., 2019. Preparation and Characterization of XRD Nano Cu-TiO₂ using Sol-Gel Method. *J. Phys. Conf. Ser.* 1185. 012020
- [24] Hardeli, Zainul, R., Isara, L.P., 2019. Preparation of Dye Sensitized Solar Cell (DSSC) using anthocyanin color dyes from jengkol shell (*Pithecellobium lobatum* Benth.) by the gallate acid copigmentation. *Journal of Physics: Conference Series* 1185(1),012021.
- [25] Yulis, R., Zainul, R., Mawardi, M.. 2019. Effect of natrium sulphate concentration on indoor lights photovoltaic performance. *Journal of Physics: Conference Series* 1185(1),012019
- [26] Anwar, M., Munaf, E., Kosela, S., Wibowo, W., Zainul, R. 2015. Study of Pb(II) biosorption from aqueous solution using immobilized *Spirogyra subsalsa* biomass. *Journal of Chemical and Pharmaceutical Research* 7(11), pp. 715-722
- [27] Zainul R, Alif A, Aziz H, Arief S, Dradjad S, Munaf E 2015 Design of Photovoltaic Cell with Copper Oxide Electrode by Using Indoor Lights, *Research Journal of Pharmaceutical, Biological and Chemical Sciences* 6(4) pp. 353-361
- [28] Zainul R 2016 Design and Modification of Copper Oxide Electrodes for Improving Conversion Coefficient Indoor Lights (PV-Cell) Photocells *Der Pharma Chemica* 8 pp. 388-395