

PROCEEDINGS
**4th International Conference on Technical
and Vocational Education and Training (TVET)**

Theme:
**Technical and Vocational Education and Training
for Sustainable Societies**

**Padang, November 9-11, 2017
at Hospitality Center
Universitas Negeri Padang**

ISBN : 978-602-1178-21-8 (1)



PROCEEDINGS

4th International Conference on Technical and Vocational Education and Training (TVET)

Theme: Technical and Vocational Education and Training for Sustainable Societies

General Chair:

- Prof. Ganefri, Ph.D. (Rector Universitas Negeri Padang)

Program Committee Chair:

- Dr. Fahmi Rizal, M.Pd., M.T. (Dean Fakultas Teknik Universitas Negeri Padang)

Steering Committee:

- Prof. Dr. Nizwardi Jalinus, M.Ed. (Universitas Negeri Padang, Indonesia)
- Prof. Dr. Ali Ghuftron Mukti, M.Sc., Ph.D. (Direktorat Jenderal Sumber Daya Ilmu Pengetahuan Teknologi Pendidikan Tinggi Kementerian RISTEKDIKTI)
- Prof. Dr. David Stein, Ph.D. (OHIO State University, USA)
- Prof. Junji Kiyono (Tottori University, Japan)
- Prof. Maizam Alias, Ph.D. (UTHM, Malaysia)
- Prof. John Williamson, Ph.D. (University of Tasmania, Australia)
- Prof. Selamat Triono Ahmad, Ph.D. (Universitas Negeri Medan, Indonesia)
- Dr. Rijal Abdullah, M.T. (Universitas Negeri Padang, Indonesia)
- Drs. Hambali, M.Kes. (Universitas Negeri Padang, Indonesia)
- Drs. Hanesman, MM. (Universitas Negeri Padang, Indonesia)
- Dr. Ir. Arwizet K, ST., MT. (Universitas Negeri Padang, Indonesia)
- Drs. Martias, M.Pd. (Universitas Negeri Padang, Indonesia)
- Drs. Raimon Kopa, MT. (Universitas Negeri Padang, Indonesia)

Scientific Committee:

- Prof. Sai Vanappali (University of Ottawa, Canada)
- Prof. Junji Kiyono (Tottori University, Japan)
- Prof. Maizam Alias, Ph.D. (UTHM, Malaysia)
- Prof. Jailani Mhd. Junos, Ph.D. (UTHM, Malaysia)
- Prof. Dr. Nizwardi Jalinus, M.Ed. (Universitas Negeri Padang, Indonesia)
- Ir. Syahril, ST., MSCE., Ph.D. (Universitas Negeri Padang, Indonesia)
- Prof. Dr. Kasman Rukun, M.Pd. (Universitas Negeri Padang, Indonesia)
- Prof. Dr. Ing. I Made Londen B (Institut Teknologi Sepuluh November Surabaya)

Reviewer:

- Prof. Dr. Nizwardi Jalinus, M.Ed. (Universitas Negeri Padang, Indonesia)
- Dr. Hansi Effendi, ST. M.Kom. (Universitas Negeri Padang, Indonesia)

- Rusnardi Rahmat Putra, ST., MT., Ph.D. (Universitas Negeri Padang, Indonesia)
- Ir. Riki Mukhayar, ST. M.T. Ph.D. (Universitas Negeri Padang, Indonesia)
- Risfendra, S. Pd. MT., Ph.D. (Universitas Negeri Padang, Indonesia)
- Krismadinata, ST. MT. Ph.D. (Universitas Negeri Padang, Indonesia)
- Dr. Asrul Huda, S. Kom. M.Kom.(Universitas Negeri Padang, Indonesia)
- Dr. Remon Lapisa, MT. M.Sc. M.Eng. (Universitas Negeri Padang, Indonesia)
- Wawan Purwanto, S.Pd. M.T., Ph.D. (Universitas Negeri Padang, Indonesia)

Editor:

- Prof. Dr. Nizwardi Jalinus, M. Ed. (Universitas Negeri Padang, Indonesia)
- Prof. Dr.Kongkiti Phusavat (Kasetsart University, Thailand)
- Prof. Maizam Alias, Ph.D. (UTHM, Malaysia)
- Prof. Dr. Ramlee Bin Musthafa (Universiti Pendidikan Sultan Idris Malaysia)
- Prof. Dr. Michael Koh, Ph.D. (Republic Politecnic Singapore)
- Krismadinata, ST., MT., Ph.D. (Universitas Negeri Padang, Indonesia)

Cover Design:

- Dr. Asrul Huda, S.Kom., M.Kom (Universitas Negeri Padang, Indonesia)

Layout:

- Dr. Remon Lapisa, MT., M.Sc. M.Eng (Universitas Negeri Padang, Indonesia)
- Rahmat Azis Nabawi, S.Pd., M.Pd.T.(Universitas Negeri Padang, Indonesia)
- Syaiful Islami, S.Pd., M.Pd.T.(Universitas Negeri Padang, Indonesia)

Cetakan :

- Kesatu, Agustus 2018

Publisher:

UNP PRESS

Jln. Prof. Dr. Hamka Air Tawar Padang
West Sumatra – Indonesia



ISBN 978-602-1178-21-8 (1)



FOREWORD

Welcome for all respected scholars, researchers, post graduate students and especially Keynote Speakers to the 4 ICTVET. The theme of the conference focus on Technical and Vocational Education and Training for sustainable societies and consist of six subthemes. i.e Development of learning model on TVET, Workplace Learning and entrepreneurship, Innovation on applied engineering and information technology, Management and Leadership on TVET, Vocational and Technical Teachers education, and Assessment and Evaluation on TVET.

Sustainable society should be followed by the improvement of various factors that have impacts to the quality of vocational and technical education and training, particularly to overcome the competitiveness of the world business. As we have already known the rapid change of technology as well as the change of demography, having a great effects to the life of peoples in this world, The competitiveness need a collaborativeness to survive the life of millions peoples who lost their jobs. Young peoples as a productive generation have to be creative and innovative to face the competitiveness. So this proceeding contents consist of various findings of research in the field of vocational and technical education as well as applied technology and mainly based on the subthemes of the conference.

Finally, we would like to thank a million for all participants of this conference and all parties who support the success of this conference. Hopefully the seminars and scientific work of this seminar can be a reference material for basic education and elementary school teacher education in Indonesia.

Padang, July 2, 2018

Tim Editor

CONTENT PROSIDING ICTVET 2017 REPOSITORY UNP

1. THE PROSPECT OF OFFSHORE IRON SAND IN TIRAM BEACH PADANG PARIAMAN REGENCY WEST SUMATERA Adree Octova, Ansosry, Yoszi Mingsi Anaperta and Indah Elok Mukhlisah.....	1-7
2. OPTIMIZE OF LEAST-SQUARE INVERSE CONSTRAIN METHOD OF GEOELECTRICAL RESISTIVITY WENNER-SCHLUMBERGER FOR INVESTIGATION ROCK STRUCTURES IN MALALAK DISTRICTS OF AGAM WEST SUMATRA Akman, Amir Harman, Putra Amali.....	8-13
3. CLUSTER ANALYSIS DISTANCE INTER DISTRICT USING SINGLE LINKAGE METHOD FOR DETERMINATION OF MPLIK CAR OPERATION ZONE IN MEDAN CITY Ali Ikhwan, Yasmin Mohd Yacob, Solly Aryza	14-16
4. EFFECT OF MIND MAPPING LEARNING METHODS ON LEARNING OUTCOMES Almasri	17-21
5. DESIGN OF SKILL ASSESMENT IN COMPUTER NUMERICAL CONTROL PROGRAMMING SUBJECT Ambiyar, Febri Prasetya, Yufrizal.....	22-26
6. MODIFICATION OF INPUT PUSHER ASSEMBLY OF LASER MARKING MACHINE Arif Rahman Hakim	27-34
7. COLLABORATIVE PROJECT-BASED LEARNING: AN INSTRUCTIONAL DESIGN MODEL IN THERMODYNAMICS ON TECHNICAL VOCATIONAL EDUCATION AND TRAINING (TVET) Arwizet K, Nizwardi Jalinus, Krismadinata.....	35-39
8. DEVELOPMENT OF EMPLOYEE INFORMATION SYSTEM-BASED WEB IN MAN 1 PADANG Asrul Huda, Rendy Harisca.....	40-46
9. DECISION SUPPORT SYSTEM (DSS) WITH WP AND MFEP METHODS IN SELECTION OF BEST BABY CLOTHES Asyahri Hadi Nasyuha, Rahmat Sulaiman Naibaho, Saniman.....	47-53
10. IMPROVING LEARNING MOTIVATION THROUGH IMPLEMENTATION PROBLEM SOLVING LEARNING STRATEGY Budi Syahri, Primawati, Syahrial	54-58
11. THE MODELING OF MASSIVE LIMESTONE USING INDICATOR KRIGING METHOD (CASE STUDIES OF MASSIVE LIMESTONE IN PT SINAR ASIA FORTUNA) Dedi Yulhendra, Yoszi Mingsi Anaperta	59-65
12. ELECTRONIC COMPONENT TESTER AS A LEARNING MEDIA FOR CLASS X STUDENTS AUDIO VIDEO ENGINEERING SMKN 1 SUMBAR Delsina Faiza, Thamrin, Ahmaddul Hadi, Yongki Saputra.....	66-74

13. EFFECTIVENESS OF INTERACTIVE INSTRUCTIONAL MEDIA ON ELECTRICAL CIRCUITS COURSE: THE EFFECTS ON STUDENTS COGNITIVE ABILITIES Doni Tri Putra Yanto, Sukardi, Deno Puyada	75-80
14. EVALUATION OF LEARNING PROCESS USING CIPP MODEL Dwi Sudarno Putra, Misra Dandi Utama, Dedi Setiawan, Remon Lapisa, Ambiyar	81-86
15. IMPLEMENTATION OF CONTEXTUAL TEACHING AND LEARNING ON ANALYZING ELECTRICAL CIRCUITS SUBJECT Dwiprima Elvanny Myori, Citra Dewi, Erita Astrid, Ilham Juliwardi	87-91
16. DOMESTIC EMPLOYMENT PROCESSING SYSTEM ON WORKING PROTECTION AND TRANSMIGRATION USING GEOGRAPHIC INFORMATION SYSTEM (GIS) Eddis Syahputra Pane, Kori Cahyono	92-98
17. CONDUCTING LABOR MARKET ASSESSMENT IN ENGINEERING CURRICULUM DEVELOPMENT Edi Septe, Suryadimal, Wenny Marthiana, Nizwardi Jalinus, Ramli.....	99-105
18. DIFFERENCES IN LEARNING OUTCOMES IN THE PRACTICE OF MICROCONTROLLER SYSTEM USING MCS51 MICROCONTROLLER TRAINER KIT Edidas, Dedy Irfan.....	106-108
19. MICROCONTROLLER SKILL TRAINING FOR SMKN 2 PAYAKUMBUH AND SMKN 1 SUNGAI RUMBAI Edidas, Legiman Slamet and Ilmiyati Rahmy Jasril.....	109-113
20. THE EFFECT OF ISLAMIC WORK ETHICS AND SPRITUAL LEADERSHIP ON EMPLOYEE'S COMMITMEN IN PADANG SHARIA HOTELS Eka Mariyanti, Rasidah Nasrah.....	114-120
21. THE DESIGNING OF THE PROTOTYPE OF THE AIR QUALITY MEASURING HELMET Eko Hariyanto, Solly Ariza Lubis, Zulham Sitorus, M. Iqbal.....	121-124
22. REVIEW DEVELOPING OF PROJECT BASED AS INNOVATION INSTRUCTIONAL Eko Indrawan	125-130
23. IMPROVING THE ESP STUDENTS' VOCABULARY BY USING PICTURES IN CIVIL ENGINEERING STUDY PROGRAM AT FIRST SEMESTER OF EKASAKTI UNIVERSITY PADANG Elda Martha Suri.....	131-133
24. INTEGRATED SERVICES SYSTEMS ELECTRONIC DEVELOPMENT FACULTY OF ENGINEERING PADANG STATE UNIVERSITY BASED ON JAVA DESKTOP Elfi Tasrif, Asrul Huda.....	134-137
25. THE EFFECT OF STRATEGY OF TRAINING MODELS IN LEARNING ELECTRICAL INSTALLATION Elfizon, Syamsuarnis, Oriza Candra.....	138-141

26. SOFTWARE DEVELOPMENT OF CONCENTRATION SELECTION WITH INTEREST TEST BASED ON INTELLIGENT SYSTEM Elin Haerani.....	142-149
27. NEEDS ANALYSIS ON INCREASING COMPETENCY TEST RESULTS STUDENTS IN S1 PROGRAM OF PUBLIC HEALTH SCIENCES STIKES HANG TUAH PEKANBARU Emy Leonita, Nopriadi, Ahmad Satria Efendi, and Niswardi Jalinus	150-155
28. THE READINESS OF STUDENT TO ENTREPRENEUR THROUGH INCORPORATION OF THE PILOT PROJECT PRACTICE Ernawati.....	156-161
29. EFFECT OF PROJECT BASED LEARNING MODEL IN IMPROVING STUDENT LEARNING RESULT Erwinsyah Simanungkalit.....	162-166
30. DESIGNING LEARNING TOOLS BY USING PROBLEM BASED INSTRUCTION (PBI) MODEL ON ENERGY RESOURCE MATERIAL INTEGRATED TO ENERGY SAVING CHARACTER Estuhono.....	167-170
31. THE DESIGN OF LECTURER PERFORMANCE EVALUATION MODEL BASED ON ANALYTIC NETWORK PROCESS (ANP) Fenny Purwani, Niswardi Jalinus, Ambiyar.....	171-175
32. DEVELOPMENT OF ONLINE EXAMINATION SYSTEM USING WONDERSHARE QUIZCREATOR BASED ON WEB Fitri Yanti, Rijal Abdullah, Krismadinata	176-180
33. THE VALIDITY OF TRAINING MATERIALS SCIENCE AND DEVICES SUBJECT AT DEPARTMENT OF ELECTRICAL ENGINEERING Fivia Eliza, Dwiprima Elvanny Myor, Hastuti.....	181-185
34. TRAINING MODEL-BASED KNOWLEDGE MANAGEMENT SYSTEM FOR VOCATIONAL HIGH SCHOOL TEACHERS SKILLS ENGINEERING COMPUTER NETWORK Gunawan Ali, Kasman Rukun, Syahril	186-193
35. FUZZY LOGIC BASED CONTROLLER FOR BUCK CONVERTER Habibullah, Irma Husnaini, Asnil.....	194-200
36. A NEW DESIGN OF HANDLESS STIRRED DEVICE Hanne Aulia, Riki Mukhaiyar	201-204
37. ACADEMIC INFORMATION SYSTEM OF STIKES PERINTIS PADANG Harleni, Marisa.....	205-209
38. DESIGN OF ELECTROMAGNETIC REGENERATIVE SHOCK ABSORBER AS A TOOL OF HARVESTING VIBRATION ENERGY ON VEHICLE Hasan Maksum, Aslimeri, Putra Jaya, Wanda Afnison.....	210-213

39. THE EFFECTIVENESS OF USING POSTER AND VIDEO MEDIA IN EDUCATION ABOUT DANGERS OF SMOKING ON KNOWLEDGE AND ATTITUDES OF SENIOR HIGH SCHOOL 12 PEKANBARU STUDENTS Hastuti Marlina, Reno Renaldi	214-217
40. A MODEL PREVENTIVE MAINTENANCE CONTROL IN THE MACHINE TURNING AT WORKSHOP THE FACULTY OF ENGINEERING OF THE STATE UNIVERSITY IN PADANG Hefri Hamid, Nizwardi Jalinus, Syahril, Ambiyar, Febri Prasetya	218-224
41. INVESTIGATION OF CHEMICAL FEASIBILITY AND DISTRIBUTION OF IRON SAND RESERVE REGIONAL AREA OF AGAM DISTRICT FOR CEMENT RAW MATERIAL IN PT. SEMEN PADANG Heri Prabowo, Sumarya.....	225-227
42. THE DEVELOPMENT OF INTERACTIVE MULTIMEDIA-BASED LEARNING MEDIA USING ADOBE FLASH CS3 AND CAMTASIA IN PROBLEM-SOLVING LEARNING IN ELEMENTARY MATHEMATICS OF IN STUDENT PGSD STKIP ADZKIA IN PADANG Ika Parma Dewi, Lativa Mursida, Rizkayeni Marta.....	228-235
43. ART EDUCATION THROUGH FREE EXPRESSION APPRECIATES, DISCIPLINE SCIENCE, AND MULTICULTURAL AS EFFORTS TO IMPROVE STUDENT CREATIVITY Indra Irawan	236-242
44. THE INFLUENCE OF USING ANIMATION MEDIA AND LEARNING MOTIVATION TOWARD LEARNING RESULT OF AUTOMOTIVE STUDENTS IN SMK N 2 PAYAKUMBUH Indra Wahyu, Fahmi Rizal, Rijal Abdullah.....	243-248
45. INFORMATION SYSTEM AND REPORT VALUE PROCESSING BASED MICROSOFT VISUAL BASIC 6.0 ON SENIOR HIGH SCHOOL (CASE STUDY AT SMAN 12 PADANG) Indra Wijaya, Isra Mouludi, Fandy Neta, Yaslinda Lizar, Satria Ami Marta	249-256
46. DESIGN OF SIMULATOR FOR REPLACEMENT OF TOOLS PRACTICE DIGITAL ENGINEERING IN THE VOCATIONAL SCHOOL Irwan Yusti, Ganefri, Ridwan	257-259
47. CELL ROTATION TO RESOLVE THE WEAKEST CELL DAMAGE IN THE BATTERY PACK IN DISCHARGING PROCESS Irwanto Zarma Putra, Citra Dewi	260-263
48. IMPROVEMENT OF CONCRETE QUALITY WITH ADDITION OF SUNUA PASIR PADANG PARIAMAN WEST SUMATRA Iskandar G. Rani, Widya Salmita.....	264-268
49. SIMPLE WATER PURIFIER USING MULTILEVEL SYSTEM Jasman, Nelvi Erizon, Syahrul, Junil Adri, Bulkia Rahim	269-272

50. DESIGN OF LIBRARY INFORMATION SYSTEM USING BARCODE ON SMAN 1 SOLOK CITY Jeprimansyah	273-280
51. THE DESIGN OF THE SIGNAL MEASUREMENT DEVICE OF BODY'S BIOELECTRICAL IMPEDANCE By USING THREE ELECTRODES Juli Sardi, Hastuti, Ali Basrah Pulungan	281-286
52. PATIENT INFORMATION SYSTEM DESIGN ON MATERNITY HOSPITAL RESTU IBU PADANG Jusmita Weriza	287-293
53. IDENTIFICATION THE IMPORTANCE OF LEARNING TOOLS DEVELOPMENT ON ENERGY-EFFICIENT BUILDING INNOVATIONS USING ROOT CAUSE ANALYSIS Kemala Jeumpa	294-297
54. DECISION SUPPORT SYSTEM FOR REKOMENDATION CERTIFICATION TEACHER ON VOCATIONAL HIGH SCHOOL Khairul, Rahmad Budi Utomo.....	298-302
55. IMPACT OF THE TWI LEARNING MODEL IN LEARNING STONE AND CONCRETE CONSTRUCTIONS ON VOCATIONAL EDUCATION Kinanti Wijaya, Daniel IrvansiusTampubolon.....	303-307
56. THE EFFECT OF SOFTWARE MASTERCAME TOWARD MECHANICAL ENGINEERING STUDENTS PERFORMANCE IN MAKING PRODUCT WITH CNC MILLING MACHINE IN VOCATIONAL HIGH SCHOOL 1 PADANG Kms. Muhammad. Avrieldi, Suparno, Nofri Helmi.....	308-310
57. LEARNING BROADCAST VIDEO SYSTEM WITH H264 VIDEO ENCODING RASPBERRY PI Leni Marlina, Aswandi.....	311-315
58. OPTIMIZATION OF EXTERNAL LIGHTNING PROTECTION SYSTEM DESIGN IN BUILDING CENTER FOR INFORMATION TECHNOLOGY AND DATA BASE (PTIPD) UIN SUSKA RIAU Liliana, Afriani, Anwardi	316-322
59. A NEW MODEL MOBILE LEARNING MANAGEMENT SYSTEM BASED ON MOODLE IN UNIVERSITY Lita Sari Muchlis, Kasman Rukun, Krismadinata, Yahfizham	323-327
60. DEVELOPMENT OF MECHANICAL TECHNOLOGY LEARNING MODULE PROGRAM EXPERTISE OF SMK ENGINEERING M. Giatman, Waskito, Maruli Sihombing	328-332
61. SECURITY OF MEDICAL RECORD WITH RIVEST SHAMIR ADLEMAN (RSA) METHOD M.Syaifuddin, Ahmad Fitri Boy, Ali Ikhwan.....	333-336
62. RAHMATAN LIL ALAMIN, THE CONCEPT OF MULTICULTURAL EDUCATION Muh. Barid Nizarudin Wajdi, Achmad Fathoni Rodli	337-340

63. LESSON STUDY FOR IMPROVING A LEARNING QUALITY Muh. Barid Nizarudin Wajdi, Andi Mursidi	341-345
64. THE ROLE OF INFORMATION TECHNOLOGY IN THE IMPROVEMENT OF TEACHER’S COMPETENCIES AND TEACHING LEARNING PROCESS EFFECTIVENESS IN ESA SEJAHTERA SCHOOL PEKANBARU Muhammad Luthfi Hamzah, Hamzah, Astri Ayu Purwati	346-350
65. IMPLEMENTATION OF PROJECT BASED LEARNING MODEL IN COURSE WEB DESIGN Muhammad Sabir Ramadhan, Neni Mulyani, Muhammad Amin.....	351-357
66. MEASUREMENT MODEL OF CONTRIBUTED FACTOR AND INDICATOR TOWARDS VOCATIONAL EDUCATION PRODUCTIVITY Mulianti, Ambiyar, Generousdi and Rodesri Mulyadi	358-364
67. ORNAMENTS ON THE TRADITIONAL ACEHNESE HOUSE IN CENTRAL ACEH, ACEH PROVINCE N Novita, M Mukhirah, R Dewi, Fitriana, F Noer, F Fadillah, E Erni.....	365-368
68. DESIGNING STRATEGY MAPS FOR PRIVATE ENGINEERING COLLEGE Nanang Alamsyah, Larisang, Muhammad Ansyar Bora	369-376
69. DESIGN OF INTERACTIVE MEDIA INTERACTIVE EYE LESSONS FOR CLASS III SD N 04 BARINGIN PADANG CULTURAL CULTURAL FLOOR BASED ON MULTIMEDIA Nelda Azhar, Putra Jaya, Asrul Huda, Etika Fahmidyah	377-383
70. DEVELOPMENT OF MALAY FRUIT ORNAMENT Netty Juliana.....	384-387
71. THE CONTRIBUTIONS OF DISCIPLINE AND ENVIRONMENTAL KNOWLEDGE ON CLEAN BEHAVIOR OF STUDENTS IN PUBLIC ELEMENTARY SCHOOL KAMPUNG BARU PARIAMAN, WEST SUMATERA Nurhasan Syah, Sanny Edinov	388-393
72. ANALYSIS OF VOLUME AND STRONG CONCRETE IMPROVEMENT ON NON- SAND CONCRETE MIXED WITH ADDITION BAKING POWDER Nurmaidah	394-398
73. BRACING CROSS SECTION EFFECT TO DISSIPATION ENERGY BY NUMERICAL ANALYSIS Prima Zola, Rahmat, Fitra Rifwan	399-405
74. DEVELOPMENT OF MODEL OF PROPELLER-CROSS FLOW WATER TURBINE FOR PICO HYDRO POWER GENERATOR TITLE Purwantono, Refdinal, Hendri, Syahrul.....	406-408
75. THE POTENTIAL OF RENEWABLE ENERGY (STUDY CASE IN TOMUAN HOLBUNG VILLAGE, ASAHAN REGENCY OF SUMATERA UTARA PROVINCE) Rahmaniar, Agus Junaidi.....	409-413

76. VIRTUAL LAB IMPLEMENTATION QOS METAROUTER ON COMPUTER NETWORK LEARNING Raimon Efendi.....	414-418
77. BLASTING DESIGN DEVELOPMENT AREA DECLINE CIBITUNG AND CIKONENG UNDERGROUND MINE PT CIBALIUNG SUMBERDAYA BANTEN Raimon Kopa, Afdhal Husnuzan, Bambang Heriya.....	419-423
78. ANALYSIS OF LEARNING COMPETENCY ENGINEERING STUDENTS VOCATION D 3 FT UNP Ramli, Febri Prasetya	424-429
79. FACTORS AFFECTING THE AUTOMOTIVE ENGINEERING STUDENTS' INTEREST ON TEACHING PROFESSION Rasinov Chandra, Anggi Aprianto, Mawardi, Reza Rahmadani.....	430-435
80. AN EXPERIMENTAL STUDY ON THE EFFECT OF CENTRIFUGAL CLUTCH COOLING GROOVE ON MOTORCYCLE PERFORMANCE Remon Lapisa, Hendika Syahputra, Irma Yulia Basri, Rifdarmon, Hendra Dani Saputra	436-440
81. EXPERT MODEL SYSTEM ON ENTREPRENEURSHIP PERSONALITY Resmi Darni, Z. Mawardi Effendi and Selamat Triono.....	441-446
82. THE ANALYZED OF TAR AS WASTE MATERIAL OF BITUMINOUS COAL GASIFICATION BY USING GASCHROMATOGRAPHY Rijal Abdullah and Hengki Ade Satria	447-450
83. EMPLOYEE PRODUCTIVITY IN TWO CROSS CULTURES BASED ENTREPRENEURSHIP Riki Adriadi, Ganefri and Fahmi Rizal	451-455
84. DEVELOPMENT OF INTERACTIVE MULTIMEDIA CD OF INSTRUCTIONAL MEDIA ON BUILDING CONSTRUCTION Rizky Indra Utama, Nurhasan Syah, Rijal Abdullah.....	456-458
85. MULTIMEDIA INTERACTIVE IN WEB PROGRAMMING SUBJECTS Rusli Saputra, Sophan Sophian, Delia Putri.....	459-464
86. PREDICTED VULNERABILITY ASSESSMENT OF NON ENGINEERED HOUSES BASED ON DAMAGE DATA OF THE 2009 PADANG EARTHQUAKE IN PADANG CITY, INDONESIA Rusnardi Rahmat Putra, Junji Kiyono and Aiko Furukawa	465-472
87. TWO SPECIES OF TERMITE DAMAGING TO BUILDING AND HOUSES AT BANDA ACEH (SUMATRA, INDONESIA) S Syauckani, M Bahi, M Muslim, M Shabri Abd Majid, D Sutekad, Y Yasmin, N Novita	473-476
88. PERSONAL MANAGEMENT IN INFORMATION SYSTEMS APPLICATIONS WITH TOGAF FRAMEWORK Safrian Aswati, Saleh Malawat, Suhendra, Iskandar, Yessica Siagian, Arridha Zikra Syah	477-482

89. ANALYZING OF TECHNICAL CUTTING OF EMPTY PALM BUNCHES Safril, Dedi Wardianto.....	483-492
90. DESIGNING AND MANUFACTURE OF RADIUS PAJI HAIRERS (PAHAT RADIUS POST) ON LATHE MACHINE FOR LABORATORY AND MODULES TEACH Saiful Anwar, Rindi Genesa Hatika, B.Herawan Hayadi.....	493-498
91. MATERIAL SELECTION ANALYSIS AND MAGNET SKEWING TO REDUCE COGGING TORQUE IN PERMANENT MAGNET GENERATOR Sepannur Bandri, M. Aldi Tio.....	499-506
92. COMPARISON OF DECISION TREE ALGORITHM METHOD (C4.5) AND NAIVE BAYES TO IDENTIFY STUDENT LEARNING RESULTS WITH COOPERATIVE LEARNING MODEL Sri Restu Ningsih.....	507-511
93. ONLINE ASSESSMENT TOOLS FOR 2013 CURRICULUM BASE ON INFORMATION TECHNOLOGY Suartin, Hambali, Oriza Chandra	512-517
94. GAME BASED LEARNING TO IMPROVMENT TEACHERS KNOWLEDGE FOR TEACHING STRATEGY IN THE CLASS Suherman.....	518-523
95. LEARNING RESPONSE OF JOURNEY LEARNING COOPERATIV LEARNING AND LEARNING MODULE IN EDUCATION MEDIA LEVEL Suparno, Bulkia Rahim, Zonny Amanda Putra, Junil Adri, Jasman	524-528
96. NEED ANALYSIS APPLICATION ON THE FEASIBILITY STUDY OF THE HYDROELECTRIC POWER SELECTION (CASE IN SOLOK, PESISIR SELATAN AND SIJUNJUNG REGENCY) Suryadimal, Edi Septe, Wenny Martiana, Fahmi Rizal, Nizwardi Jalinus.....	529-534
97. DEVELOPING SOFT SKILLS LEARNING MODELFOR MECHANICAL ENGINEERING STUDENTS OF VOCATIONAL HIGH SCHOOL Suryo Hartanto	535-538
98. IMPACT OF WORK-BASED LEARNING OF CONCRETE STONE WORK PRACTICE ON DIPLOMA-III CIVIL ENGINEERING STUDENTS Syafiatun Siregar	539-543
99. DEVELOMPENT OF WEB-BASED DECISION SUPPORT SYSTEM FOR SCHOLARSHIP RECIPIENTS SELECTION USING ANALYTICAL HIERARCHY PROCESS (AHP) METHOD Titi Sriwahyuni, Dedi Irfan, Ika Pharma Dewi and Hanny Maharani.....	544-552
100. EFFECT OF ENGINE TEMPERATURE CHANGES ON INJECTION TIME OF FUEL AND GAS EMISSION OF GASOLINE ENGINE Toto Sugiarto, Dwi Sudarno Putra, Wawan Purwanto	553-557

101. EARTHQUAKE AND TSUNAMI DISASTER MITIGATION TRAINING FOR ELEMENTARY SCHOOL STUDENTS IN THE COASTAL AREA OF PADANG PARIAMAN DISTRICT WITH KYOTO INTERNATIONAL DISASTER PREVENTATION SCHOOL METHOD Totoh Andoyono, Fitra Rifwan, Revian Bodi, Prima Zola, Annisa Prita.....	558-560
102. FUNCTIONAL MEMBERSHIP ANALYSIS OF FUZZY INFERENCE SYSTEM SUGENO IN ANEMIA CLASSIFICATION Tri Monarita Johan	561-563
103. DEVELOPMENTAL OF MEDIA LEARNING BASED ON TUTORIAL VIDEO AT CHARACTER MAKE UP SUBJECT IN SMKN 6 TyasAsih Surya Mentari, MurniAstuti, and Linda Rosalina	564-570
104. PSYCHOLOGICAL FACTORS INFLUENCING THE DECISION MAKING OF PURCHASING PRODUCTS VIA ONLINE Ulfa Annida Damanik, Sri Wening	571-577
105. IMPROVING TEACHERS' PROFESIONALISM APPROPRIATE TO NEW CURRIRULUM 2017 FOR VOCATIONAL SCHOOLS BY CAPACITY BUILDING AND WORKSHOP ABOUT PREPARING LOCAL GOVERNMENT FINANCIAL STATEMENT; AN EXPERIMENTAL STUDY ON ACCOUNTING TEACHERS' FROM VOCATIONAL SCHOOLS IN WEST SUMATERA PROVINCE Vita Fitria Sari, Mayar Afriyenti, Mia Angelina Setiawan	578-585
106. THE DEVELOPMENT OF VIT (VOCATIONAL INTEREST TEST) MODEL USING DECISION SUPPORT SYSTEM (DSS) TECHNIQUE Vitriani.....	586-590
107. ANALYSING INFORMATION SYSTEM OF ACADEMIC SERVICES IN THE UNIVERSITY Wahyu Prima, Ganefri, Krismadinata	591-595
108. RESOURCE SHARING–BLENDED PROJECT BASED LEARNING (RS-BPBL©) MODEL DEVELOPMENT IN VOCATIONAL HIGH SCHOOL Wahyudi	596-602
109. DEVELOPMENT ASSESSMENT MODEL TO HIGH ORDER THINKING SKILL ORIENTATE FOR EVALUATION STUDENT COMPETENCY Wakhinuddin S, Bahrul Amin, Waskito.....	603-605
110. USE OF GEARBOX VIAR ON FISHING SHIPS Wakhinuddin S, Donny Fernandez, Andrizal, M Nasir, Rifdarmon	606-609
111. THE APPLICATION OF SIMPLE STRAIN GAUGE DYNAMOMETER IN LEARNING STYLE CUTTING LATHE Wenny Marthiana, Suryadimal, Edi Septe, Duskiardi, Andika.....	610-613
112. DESIGN OF ANDROID BASED INTERACTIVE BOOK IN INTEGRATED ISLAMIC ELEMENTATY SCHOOL OF LAN TABUR PAGARALAM CITY Yadi, Efan, Sigit Candra Setya.....	614-617

113. SMART CLASSROOM DESIGNS IN THE SMART EDUCATIONAL ENVIRONMENT Yasdinul Huda, B Herawan Hayadi	618-626
114. BUILD AND DESIGN OF BUSINESS INTELLIGENCE UNIVERSITY SYSTEM AS DECISION SUPPORT ACADEMIC Yaslinda Lizar, Asriwan Guci	627-636
115. SOIL STABILITY USING CEMENT PCC IN LUBUK MINTURUN PADANG, INDONESIA Yocky Syaida Adha Putra, Tengku Ahmad Fauzan Syah	637-642
116. INFLUENCE THE LEARNING STRATEGY AND ENTRY BEHAVIOR TO YIELD LEARNING BUILDING CONSTRUCTION AND DRAWING 1 OF STUDENT Yuwalitas Gusmareta, Fahmi Rizal, Nurhasan Syah.....	643-646
117. IMPLEMENTATION OF DISASTER PREPARED SCHOOL (SSB) IN WEST PASAMAN DISTRICT WEST SUMATERA PROVINCE Yuwalitas Gusmareta, NurhasanSyah, Laras Andreas Oktavia, RizkyIndraUtama, MuviYandra.....	647-649
118. USING MOBILE TELECOMMUNICATIONS -2000 INTERNATIONAL FOR ANALYZING TECHNOLOGY NETWORK ERA 4G-LTE ZulhamSitorus, Ganefri, NizwardiJalinus	650-653
119. FACTORS AFFECTING STUDENTS IN CHOOSING COMPUTER ENGINEERING DEPARTMENT IN STT PAYAKUMBUH Zulkifli, Dilson, Rahmad Al Rian	654-659
120. FACTORS EFFECTING ELEMENTARY SCHOOL TEACHER READINESS ON IMPLEMENTING CURRICULUM IN WEST SUMATERA Zuryanty, Hamimah, Mulyani Zein.....	660-665

DESIGN OF ELECTROMAGNETIC REGENERATIVE SHOCK ABSORBER AS A TOOL OF HARVESTING VIBRATION ENERGY ON VEHICLE

Hasan Maksum¹, Aslimeri², Putra Jaya³ and Wanda Afnison¹

¹Department of Automotive Engineering, Faculty of Engineering, Universitas Negeri Padang

²Department of Electrical Engineering, Faculty of Technology, Universitas Negeri Padang

³Department of Electronic Engineering, Faculty of Technology, Universitas Negeri Padang

ABSTRACT: This article discusses vibration energy on the vehicles shock absorber which was converted to electrical energy by using magnet and coil. Principally, vibration energy on the shock absorber will be wasted into friction and heat form. But, we are able to obtain the vibration energy and utilize it as a new energy source for the vehicle by adding the mechanism of harvesting energy electromagnetic type. Linear movement of the shock absorber is captured by electromagnetic generator mechanisms which are consist of a coil and a permanent magnet. The produced output of the electromagnetic generator can be used as new energy source for the vehicle. The mechanism of harvesting energy used electromagnetic generator was chosen through literature study that has been done by the researcher. Which was electromagnetic generator has the smallest of loss of energy value of all type of harvesting energy. The testing data which used galvanometer, it was obtained that the resurrection energy was 2.5 mV on 1.5 Hz excitation frequency, 4.24 mV on 2.0 Hz excitation frequency and 5.6 mV on 2.5 Hz excitation frequency.

Keyword: shock absorber, harvesting energy, electromagnetic generator,

1. INTRODUCTION

Based on the data which was obtained on Center for Energy, Transportation and the Environment (CETE), it is known that vehicles will work effectively using 16% of fuel energy from the result of combustion used. The rest 62% will be engine losses in heat and vibration form, 11% engine idling, 6% transmission losses, and 2% from the adding of accessory such as Air Conditioner (AC), wiper, etc. Shock absorber is a component which is used as the pedestal of vehicle's body and to isolate the vehicle from the vibration cause of the road's contour. The changes of mechanism energy happened on the conventional shock absorber (up and down energy of vehicle's body) into heat energy which was happened because the movement of fluid on the shock absorber. Meanwhile, the design changes happened on the electromagnetic regenerative shock absorber which was the up and down energy on the shock absorber captured and changed it into excitation energy to actuate the electromagnetic mechanism which is set on the Shock absorber. So, the loss energy on the shock absorber can be reused. This regenerative shock absorber is expected to be able to keep down the loses energy value on the heat and vibration sector which is 62% until the efficiency value of vehicle increase.

2. LITERATURE REVIEW

There are several studies relate to a Regenerative shock absorber which was used as the background of this article. One of them is Li Chuan, et al [1] with regenerative shock absorber by using hydraulic

rectifier as rectification flow and then go through the hydraulic motor.

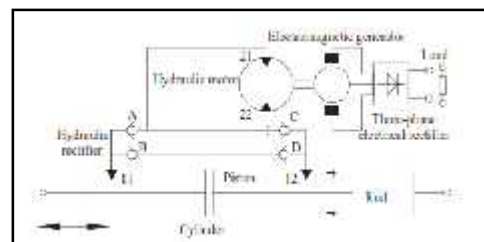

Picture 1. Regenerative shock absorber with a hydraulic motor

Compression and rebound movement of the shock absorber is rectified through a rectifier and then goes to the hydraulic motor. The function of the hydraulic motor is to spin the generator. The source of motor movement on the generator is obtained from the pressure fluid which has come from the rectifier. The generator spin produces electrical energy which is used as a new energy source.

Next, a shock absorber liquid damper type [2] from Indian Institute of Technology.

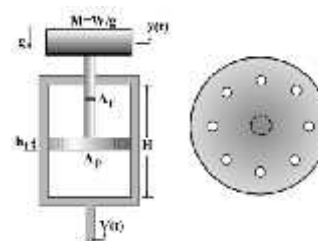

Picture 2. Liquid damper shock absorber

From the test, it was obtained that the damping energy is a nonlinear curve. This is the damping energy's value of the test:

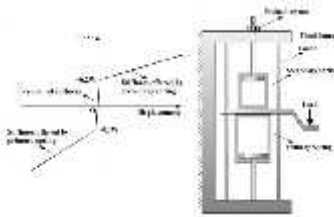

Picture 3. Force dumper curve of liquid dumper shock absorber

Last, HEMSA (Hydraulic Electro Mechanic Shock absorber) from Institut Teknologi Sepuluh Nopember [3]. The following picture is the design of HEMSA from Institut Teknologi Sepuluh Nopember

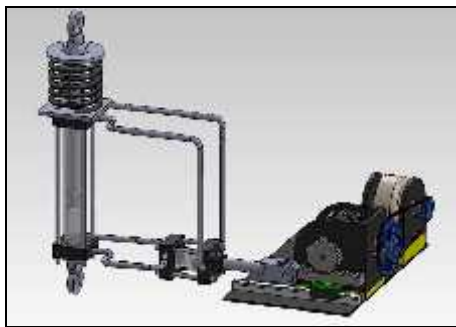

Picture 4. Hydraulic Electro Mechanic Shock absorber (HEMSA) from ITS

From the test with the load 85 , 125 , 250 , it was obtained the resurrection energy on 1.7 Hz excitation frequency in sequence based on the load, are 0,52 watt, 0,39 watt, 0,32 watt. With the cylinder variation 40:40, double port pipe and 85 , 125 , 250 load, it was obtained velocity sprung mass value in sequence based on the load, are 2.270 m/s², 2.084 m/s², 1.744 m/s².

Based on those literature sources, the writer was interested to make a regenerative shock absorber with the electromagnetic mechanism. Besides the simple construction design, this electromagnetic system also has a small loss of energy.

3. BASIC THEORY

3.1 Harmonic Vibration

Usually, vibration not only occurs on the spring system nor the prop, the base of the system will also experience the vibration in harmonic vibration form.

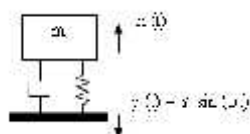

Picture 5. Excitation on the base

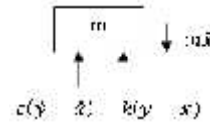

Picture 1. Free Body Diagram excitation on the base

From the free body diagram on picture 5 and excitation on the base on picture 6, the equation of movement that was obtained is:

$$m\ddot{x} + c(\dot{x} - \dot{y}) + k(x - y) = 0$$

The Steady-state response of the mass is $x_p(t)$ which is can be formed into this following equation:

$$x_p(t) = \frac{kY \sin(\omega t - \theta_2)}{[(k - m\omega^2)^2 + (c\omega)^2]^{1/2}} + \frac{\omega c Y \sin(\omega t - \theta_1)}{[(k - m\omega^2)^2 + (c\omega)^2]^{1/2}}$$

So, the system equation above can be written as:

$$x_p(t) = X \sin(\omega t - \theta_1 - \alpha) = \left[\frac{k^2 + (c\omega)^2}{(k - m\omega^2)^2 + (c\omega)^2} \right]^{1/2} \sin(\omega t - \theta_1 - \alpha)$$

Where the value of $\theta_1 = \tan^{-1} \left(\frac{c\omega}{k - m\omega^2} \right)$

That equation can be simplified into:

$$x_p(t) = X \sin(\omega t - \theta)$$

Where $\frac{X}{Y}$ is displacement transmissibility:

$$\frac{X}{Y} = \left[\frac{k^2 + (c\omega)^2}{(k - m\omega^2)^2 + (c\omega)^2} \right]^{1/2} = \left[\frac{1 + (2\zeta r)^2}{(1 - r^2)^2 + (2\zeta r)^2} \right]^{1/2}$$

And,

$$\theta = \tan^{-1} \left[\frac{m\omega^2}{k - m\omega^2} \right] = \tan^{-1} \left[\frac{2\zeta r^2}{1 + (4\zeta^2 - 1)r^2} \right]$$

The relevance of damping ratio, frequency ratio, and displacement transmissibility is shown in the following graphic:

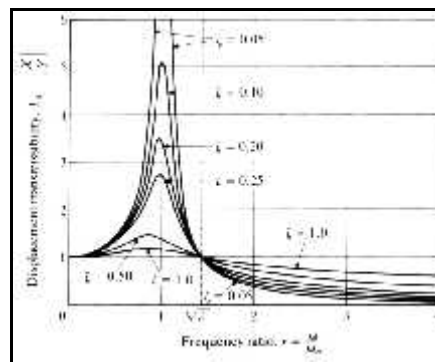

Picture 2. Displacement transmissibility vs frequency ratio

3.2 LOGARITHMIC DECREMENT

Logarithmic decrement is a display of amplitude reduction on free damp vibration. The value of damping constant on the system will be known if the logarithmic decrement (δ) is also known.

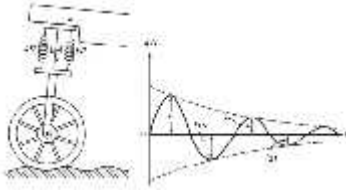

Picture 8. System 1 DOF on vehicle's shock absorber with its damper and system experiment analysis

From the picture above, t is known as time on the first and second peak, x_1 dan x_2 show the peak movement, and form the ratio:

$$\frac{x_1}{x_2} = e^{2\pi\zeta / \sqrt{1-\zeta^2}}$$

If both parts of logarithm were naturalized, it will be:

$$\delta = \ln \frac{x_1}{x_2} = \frac{2\pi\zeta}{\sqrt{1-\zeta^2}}$$

The equation above can be written as:

$$\zeta = \frac{\delta}{\sqrt{(2\pi)^2 + \delta^2}}$$

From displacement graphic, the function of time will be obtained from x_1 and x_2 , and then the value will be included in decrement equation, so the equation will be:

$$\zeta = \frac{\delta}{\sqrt{4(\pi)^2 + \delta^2}}$$

Where: = damping ratio

= logarithmic decrement = $\ln \frac{x_1}{x_2}$

The value of damping ratio can be found by using this formula:

$$\zeta = \frac{c}{c_c} = \frac{c}{2\sqrt{km}}$$

Where: k = Spring content (N/m)
 C = Damping constant
damping
 m = Load mass (kg)

3.3 The effect of vehicle's velocity toward human

The main movements that were experienced by the driver and passenger during the ride are velocity or deceleration and vibration. Endurance information about human body toward the velocity is very important as references on the endurance of vehicle's body design toward the impact.

The pleasure criteria based on velocity number according to ISO 2631 standard, will be shown in this following graphic:

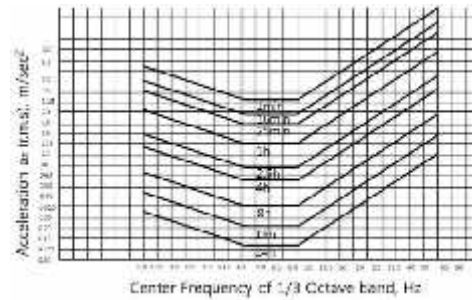

Picture 9. The pleasure criteria graphic based on ISO 2631 standard

3.4 Loretz Law

The permanent magnet array of regenerative the electromagnetic shock absorber is connected to wheel axles of the vehicle and the coil windings array is connected to the framework or body of the vehicle. When the vehicle travels on rough roads, the relative displacement between framework or body and wheel axles causes relative displacement between coil windings array and permanent magnet array. At this point coil groups will be cutting the magnetic induction lines in the air-gap, thus current occurs in the coil and in the meantime damping force occurs correspondingly. The direction of the damping force is relatively opposite to the movement of the coil group. When the conductor moves perpendicularly to the direction of magnetic induction line, the Lorentz force can be defined as:

$$F = q \cdot V \cdot B$$

Where: F = Lorentz force (N)

q = quantity of electricity (C)

V = Velocity of electric charge (m/s)

B = Magnetic flux density (T)

4. DESIGN AND PARAMETER

4.1 Coil

The coil is used as a track movement of the permanent magnet. This coil will capture GGL from the result of magnet movement in it. This is the design of coil R



Picture 10: Coil

4.2 Permanent Magnet

This magnet is used as a moving component which is installed in the rod shock absorber. The rod movement which was installed the permanent magnet on the coil will cause the electricity force. This is the construction of permanent magnet on the rod shock absorber.



Picture 11: Permanent magnet

4.3 Full design concept

On this part, it is shown that the mechanism of harvesting energy attachment on the up and down rod movement which pass the coil.

Picture 12: Component detail RSA
When it assembled and ready to test:

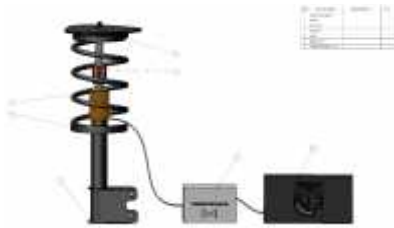

Picture 13: RSA assembly ready to test

4.3 Research Methodology

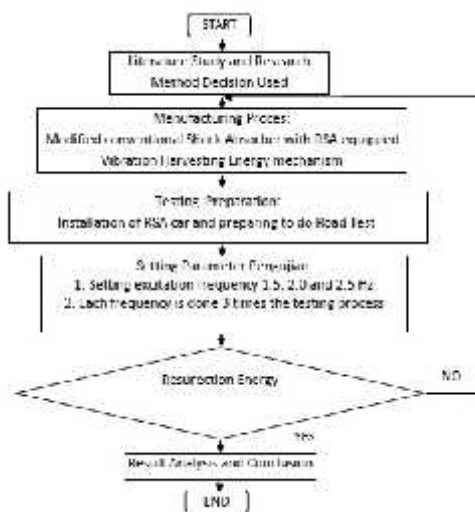

Picture 14: Research Methodology

5. RESULT

From the road test by using bump 50 mm high to replace the road surface, the resurrection energy that was obtained on RSA are:

No	Frequency	Energy Resurrection			
		Test I	Test II	Test III	Average
1	1.5 Hz	2.3	2.6	2.5	2.5 mV
2	2.0 Hz	4.30	4.37	4.1	4.24 mV
3	2.5 Hz	5.4	5.8	5.6	5.6 mV

6. CONCLUSION

The resurrection energy from RSA is relatively small. It was caused by the limitation of the step length of the “stroke” area from the permanent magnet on passing the coil area. To wider the length of its step, we need to do a redesign and choose better material in order to get bigger resurrection energy.

7. REFERENCES

- [1] Anderson, Peter. (2011). "Global Energy Consumption Due to Friction in Passenger Cars". VTT Technical Research Centre of Finland, Finland
- [2] Bart L.J. Gysen dkk. 2010. Active Electromagnetic Suspension System for Improved Vehicle Dynamics, Eindhoven University of Technology, Netherlands.
- [3] Laksana Guntur, Harus. 2013. Development and Analysis of a Regenerative Shock Absorber for Vehicle Suspension. JSME Journal of System Design and Dynamics.
- [4] S. Rao, Singiresu. 2004. Mechanical Vibration. Prentice Hall PTR. Singapore.
- [5] Sutantra, I Nyoman, 2012., Teknologi Otomotif Edisi Kedua. Institut Teknologi Sepuluh Nopember, Indonesia.
- [6] W. Fox, Robert. Introduction to Fluid Mechanics 7th edition. John Wiley & Sons. The USA.
- [7] Zhigang Fang, dkk. 2013. Experimental Study of Damping and Energy Regeneration Characteristics of a Hydraulic Electromagnetic Shock Absorber. Wuhan University of Technology. China